

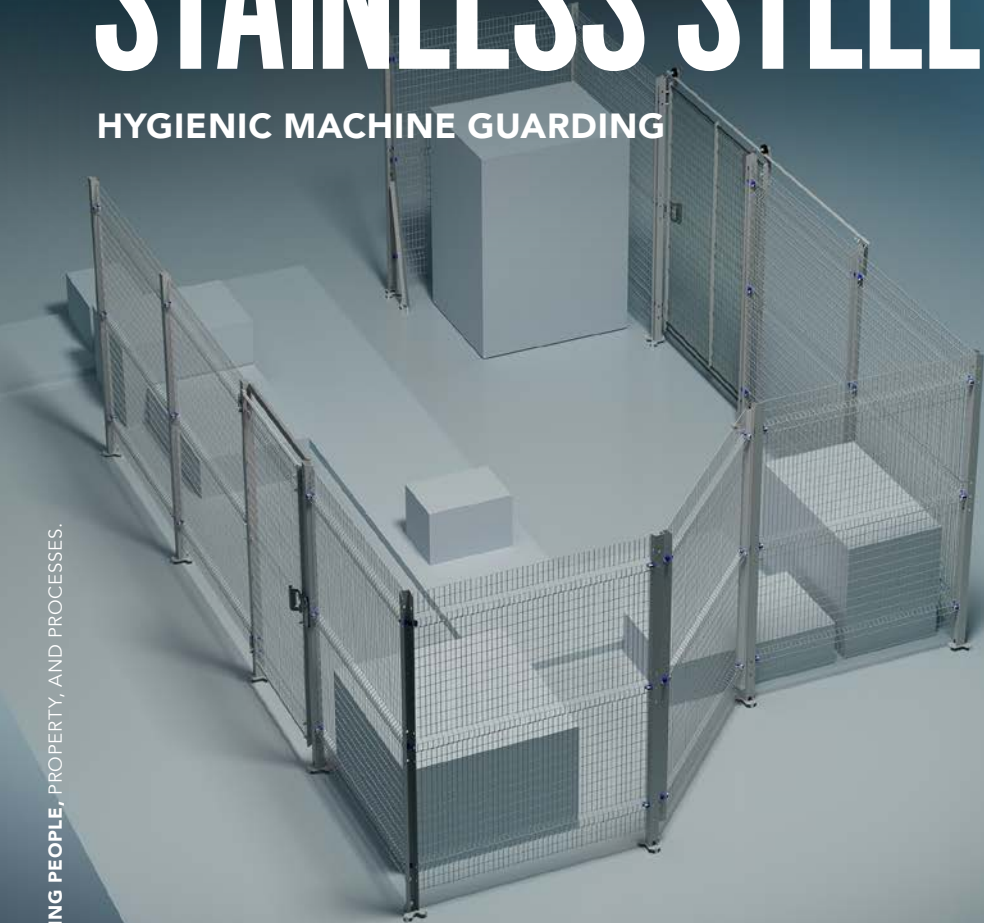

BLUEGUARD STAINLESS STEEL

HYGIENIC MACHINE GUARDING



PROTECTING PEOPLE, PROPERTY, AND PROCESSES.

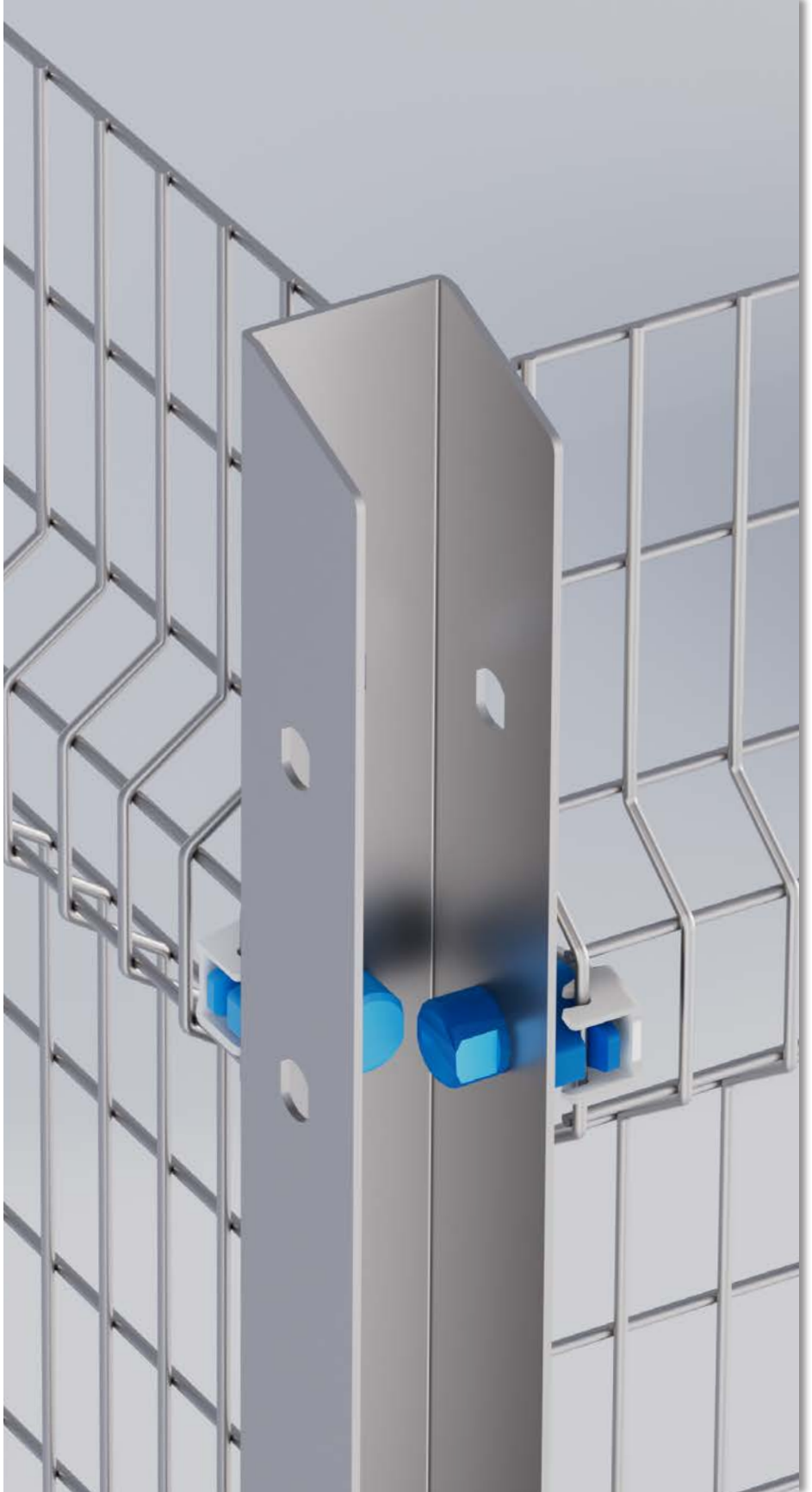

MAXIMUM SAFETY. MAXIMUM HYGIENE.

The BlueGuard modular system is the result of years of experience within Troax Group. It combines safety, flexibility and compliance with the highest hygiene standards required by the agro-food, chemical and pharmaceutical markets.

The 4 mm welded wire panel is frameless, and strengthened by transversal folds. It is constructed of AISI 304 L stainless steel, which is finished by passivation. When assembled, the panel is fixed to

an open and washable U-shaped post. The panels are fastened with high-resistant, captive fixings fabricated with techno-polymer and stainless steel.

BlueGuard is quick to assemble: a single, universal post for linear, angular and door mounting, reduces set up time and increases flexibility. Wide access points facilitate the use of power tools, while the frameless construction allows panel sizes to be modified easily and quickly on site.

600 JOULES IMPACT TESTED

THE PENDULUM TEST

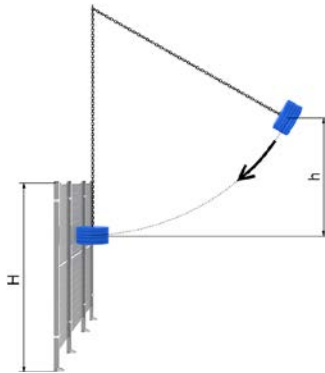

ROBUST

- » Stainless Steel AISI 304 L
- » Techno-polymer fixings
- » Resistant to high-pressure water jets

EASY INSTALLATION

- » Quick fastening system
- » Frameless, for easy adaptations on site
- » Capitive fixings

HYGIENIC

- » Easy inspection
- » Suitable in aggressive environments
- » **ECOLAB** Tested and Certified

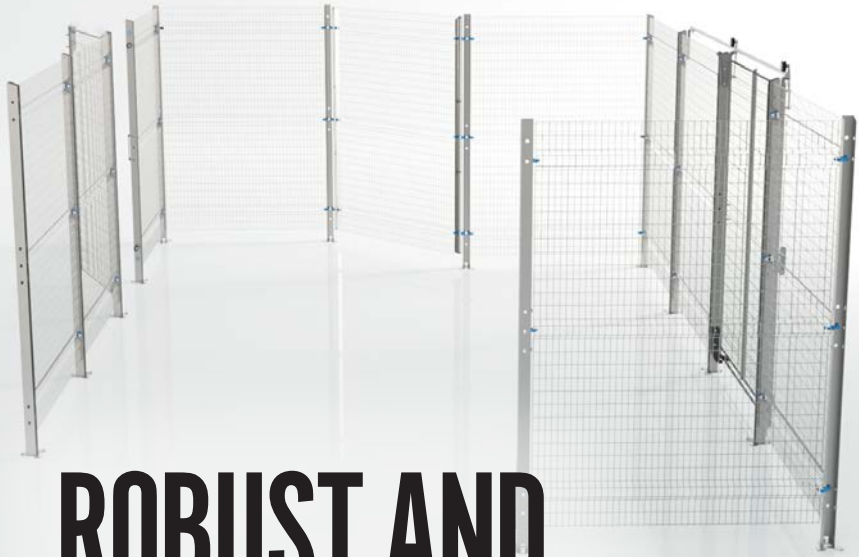

ROBUST AND CLEAN DESIGN.



OPEN DESIGN
Inclined surfaces prevent accumulation of dust and residue.



HYGENIC FIXINGS
Techno-polymer fixings minimize metal-to-metal contact, avoiding cavities.



REDUCE SURFACE CONTACT
The floor spacers help to avoid liquid pooling, enabling easier and more efficient cleaning.



**DETERGENT AND DISINFECTANT
RESISTANCE TESTS FOR
2,000 WASHING CYCLES
(6 YEARS OF USE) ON:**

TOPAZ AC5	P3-TOPAX 66
P3-TOPAX 990	TOPAZ HD3
TOPACTIVE DES	TOPAZ MD3

DURABLE.

- RESISTANT TO HIGH-PRESSURE WATER JETS
- CORROSION RESISTANCE AT THE AISI 304 L LEVEL

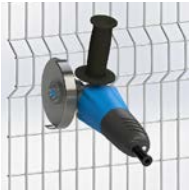

FLEXIBLE AND FULLY ADAPTABLE

The frameless panels can easily be adapted on-site.

GREATER STABILITY

Panels made of 4 mm welded wire and strengthened by transversal folds.

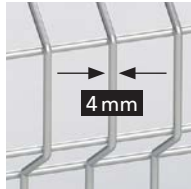

PANELS

Mesh aperture: 32×68×4 mm
Height: 2,080 mm
Widths: 484, 996, 1,476, 1,988 mm

POSTS

Universal U-shaped: 60×60 mm
Baseplate: Continuous TIG welded with 3 anchoring points
Height: 2,240 mm including spacers

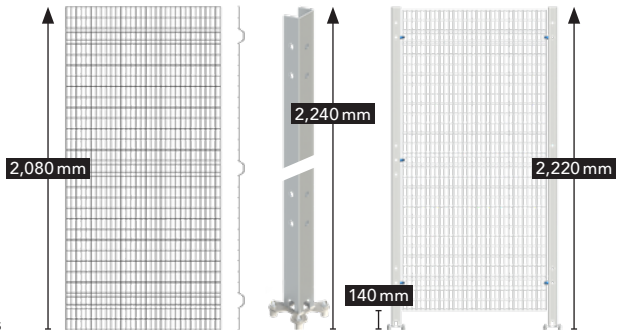

DOORS.

SINGLE HINGED DOOR

- » 800 or 1,000 mm framed door leaves.
- » Hygienic design with inclined surfaces.
- » Magnetic Lock and brackets for safety switches as option.



DOUBLE HINGED DOOR

- » 800 + 800 or 1,000 + 1,000 mm framed door leaves.
- » Hygienic design with inclined surfaces.
- » Magnetic Lock and brackets for safety switches as option.

SINGLE SLIDING DOOR

- » 1,500 or 2,300 mm framed door leaves.
- » Hygienic design with inclined surfaces and low friction upper trolley.
- » Magnetic lock and brackets for safety switches as option.



ACCESSORIES.

- SUPPORT FOR POST
- VARIABLE ANGLE KIT
- SAFETY SWITCH BRACKETS
- ADJUSTABLE FOOT
- SUPPORT FOR ADJUSTABLE FOOT



SUPPORT FOR POST



ANGLE PROFILE



SAFETY SWITCH BRACKET

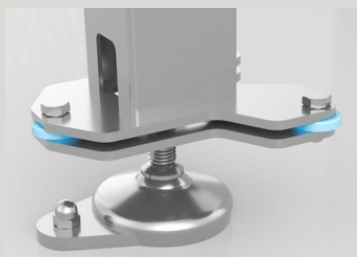

ADJUSTABLE FOOT



SUPPORT FOR ADJUSTABLE FOOT

A SAFER TOMORROW
■ SINCE 1955 →

